

Operator Tracks

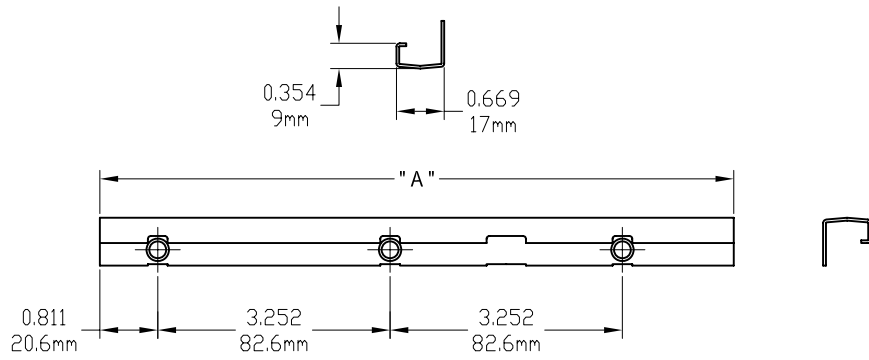

Single Arm Operator Track 3 holes		
Part Number	" A "	Material
70039	8.874"	SST
190039	8.874"	Steel

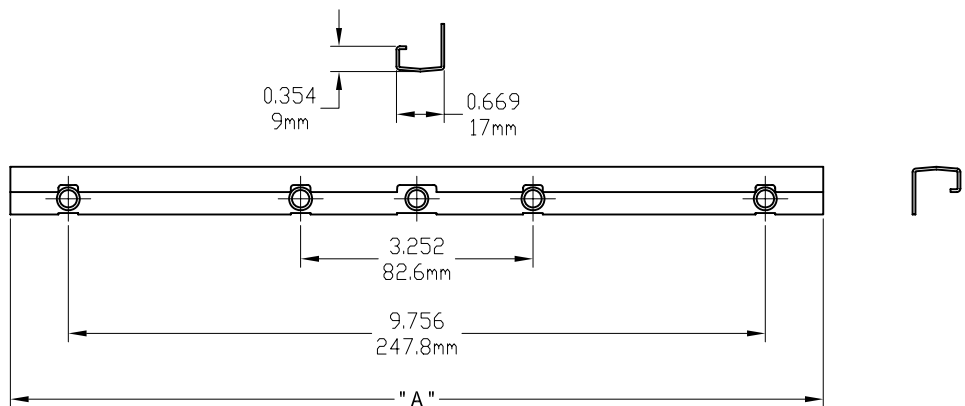

Single Arm Operator Track 5 holes		
Part Number	" A "	Material
70040	11.378"	SST
190040	11.378"	Steel

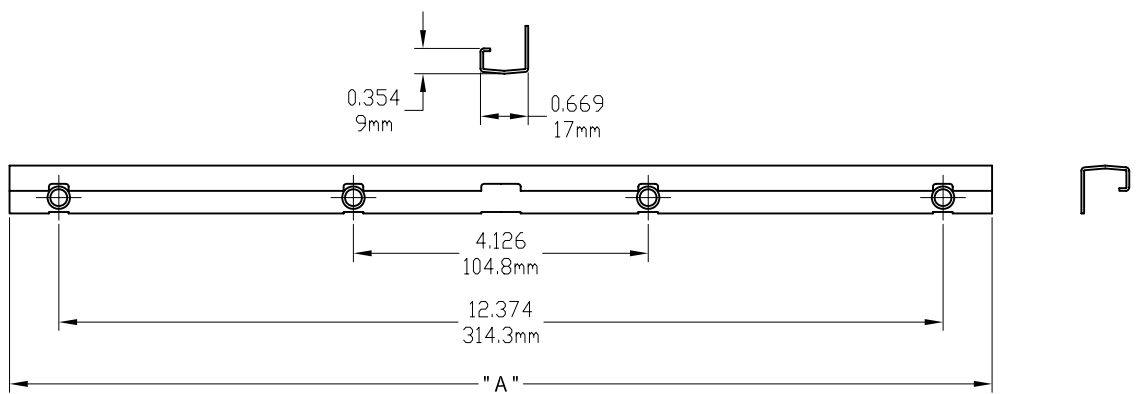

Single Arm Operator Track 4 holes		
Part Number	" A "	Material
70041	13.752"	SST
190041	13.752"	Steel

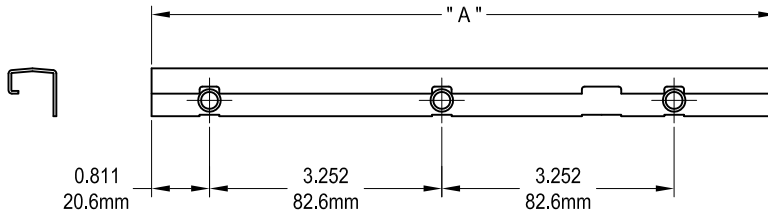
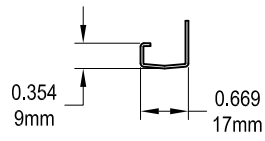

Single Arm Operator Track 3 holes		
Part Number	" A "	Material
70042	8.748"	SST
190042	8.748"	Steel

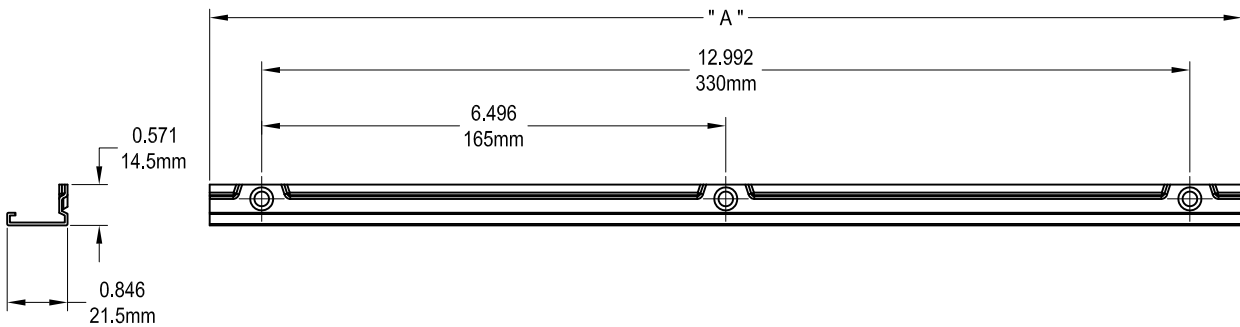

Dual Arm Operator Track 3 holes		
Part Number	" A "	Material
70051R1	14.449"	SST
190051R1	14.449"	Steel

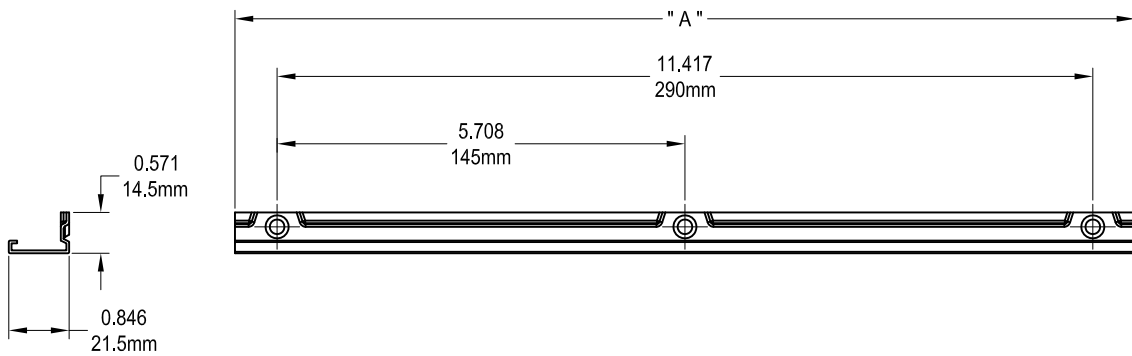

Dual Arm Operator Track 3 holes		
Part Number	" A "	Material
70052R1	12.598"	SST
190052R1	12.598"	Steel

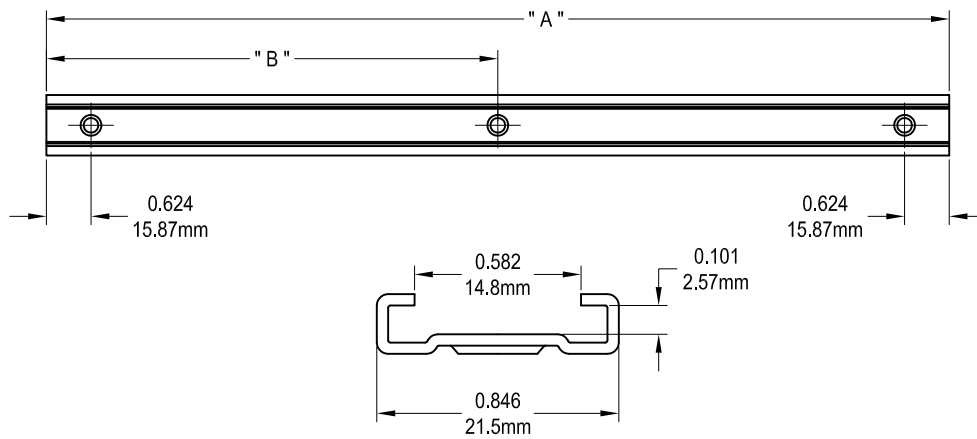

Dual Arm Operator Track 3 holes			
Part Number	" A "	" B "	Material
70061	12.637"	6.319"	SST
70062	14.448"	7.224"	SST
70063	15.374"	7.689"	SST

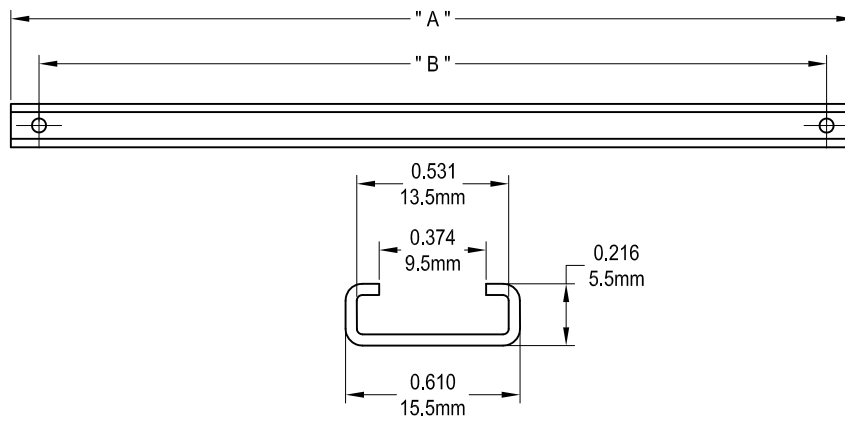

Single Arm Operator Track 2 holes			
Part Number	" A "	" B "	Material
70300	11.811"	11.023"	SST
70350	13.779"	12.992"	SST
70400	15.748"	14.960"	SST

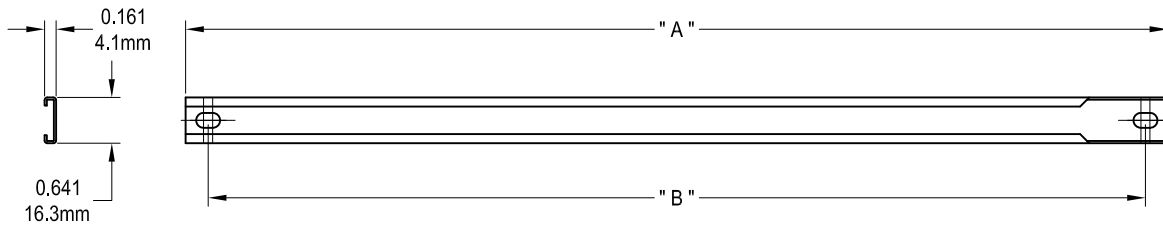

Single Arm Operator Track 2 holes			
Part Number	" A "	" B "	Material
70055	13.75"	13.12"	SST
70056	17.795"	17.165"	SST
70064	9.126"	8.5"	SST
70065	11.626"	11.0"	SST
70054	9.5"	8.87"	SST

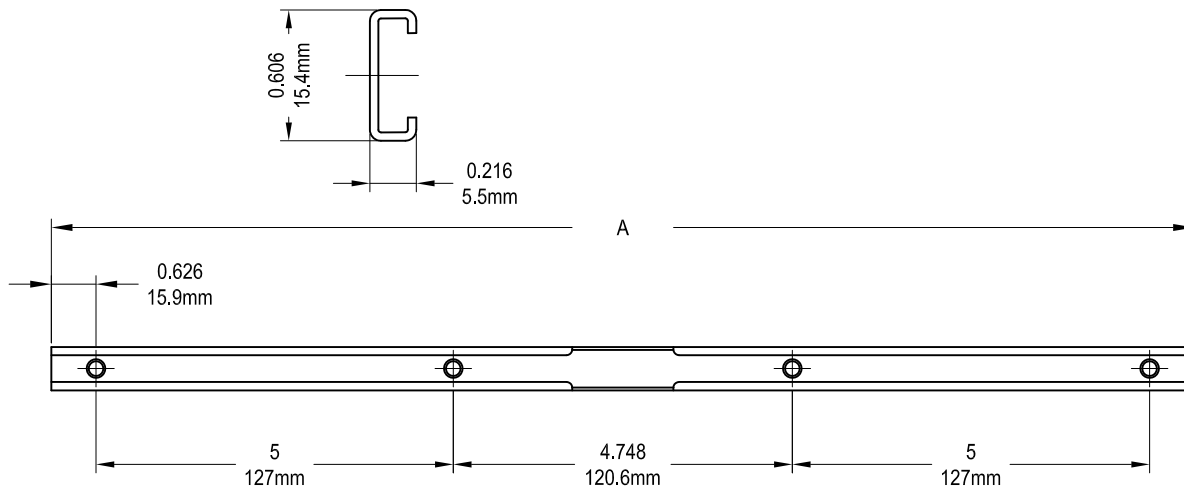

Arming Operator Track 4 holes		
Part Number	" A "	Material
70030	16"	SST
190030	16"	Steel

Dual Arm Operator (Low Profile) Track 190056

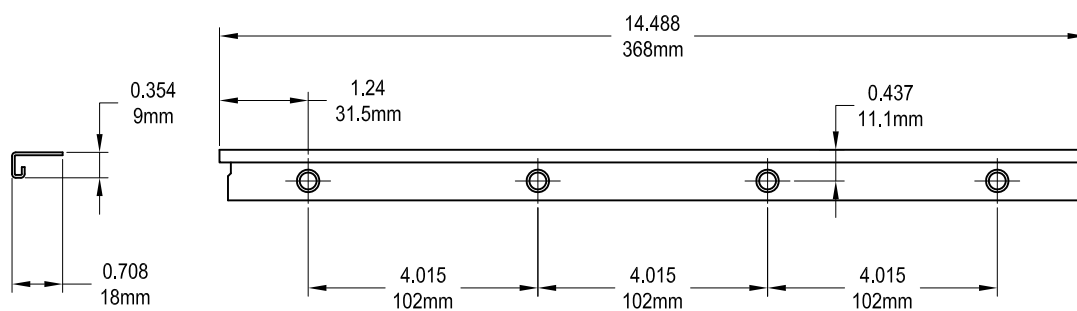

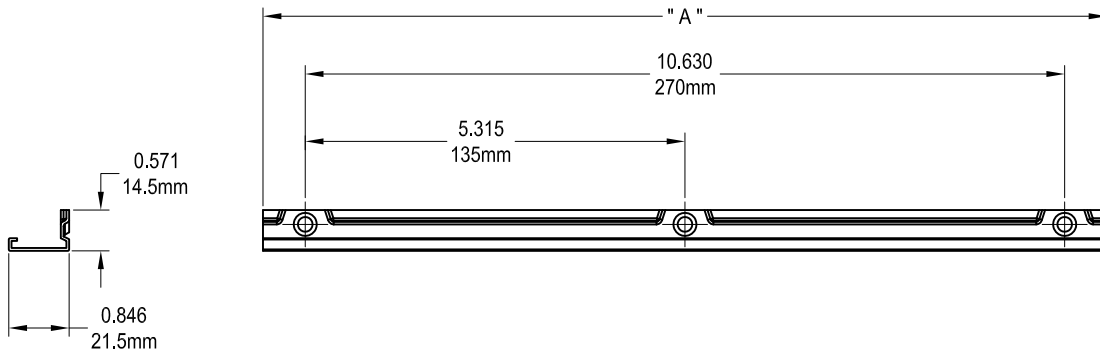

Dual Arm Operator Track 3 holes		
Part Number	" A "	Material
70053R1	11.811"	SST
190053R1	11.811"	Steel

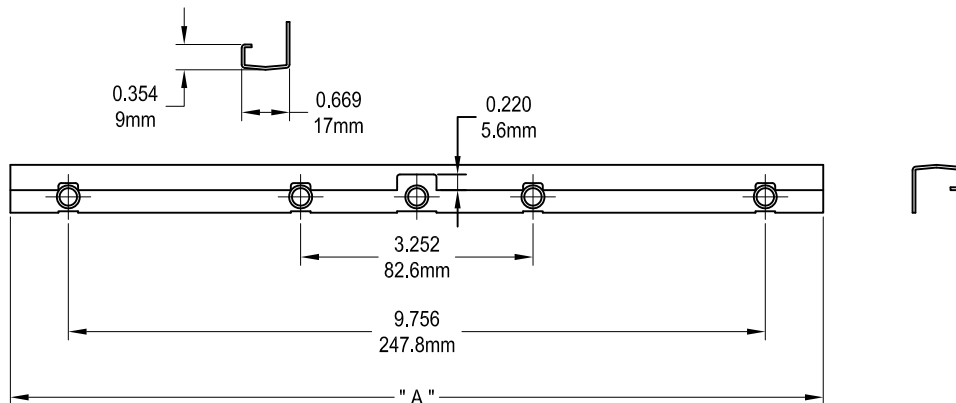

Single Arm Operator Track 5 holes		
Part Number	" A "	Material
70040-A	11.378"	SST
190040-A	11.378"	Steel

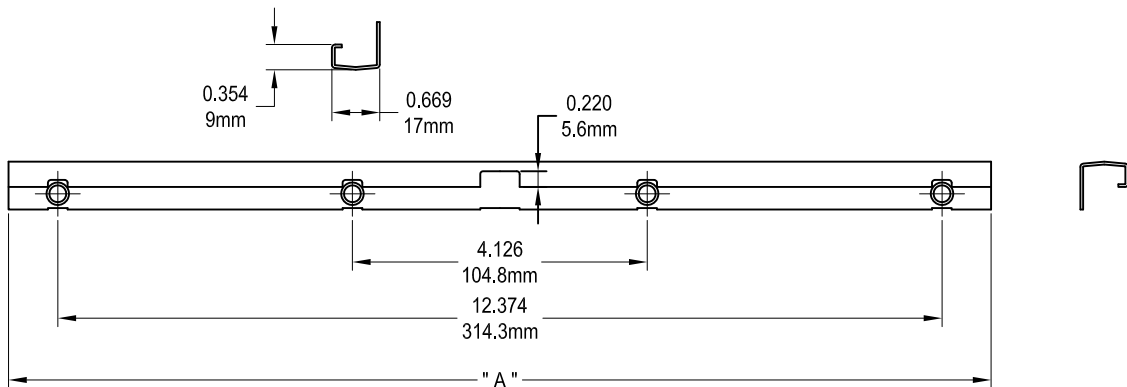

Single Arm Operator Track 4 holes		
Part Number	" A "	Material
70041-A	13.752"	SST
190041-A	13.752"	Steel

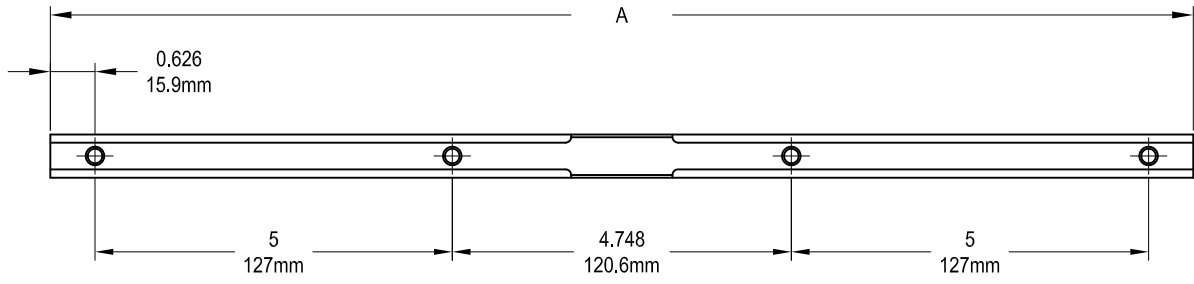
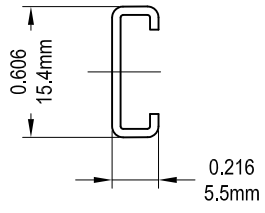

Arming Operator Track 4 holes		
Part Number	" A "	Material
70030	16"	SST
190030	16"	Steel